

# Zone Monitor 3000

## Installation and Operation Manual

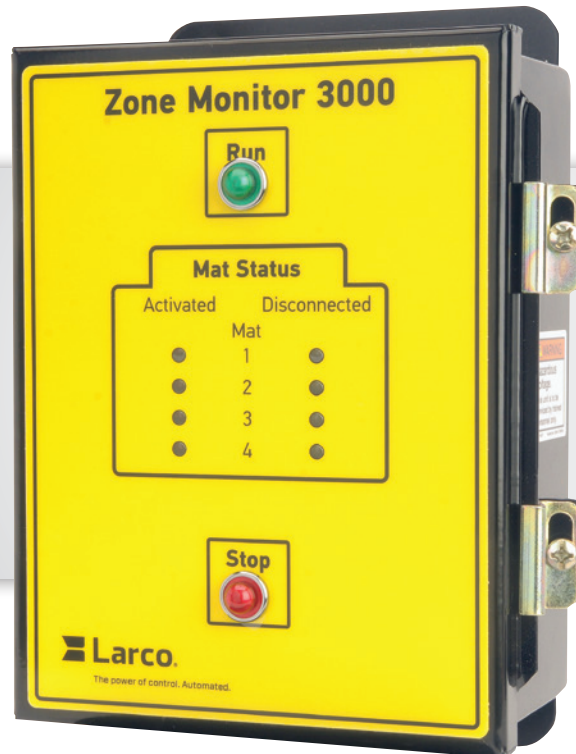

Important Safety Message .....	3
Zone Monitor 3000 Overview .....	3
Installation Instructions .....	5
Testing and Using the System .....	11
Troubleshooting Guide .....	13
Controller Specifications .....	14
Details and Dimensions .....	15

### Important Safety Message

Minimizing the hazards surrounding heavy automated equipment and industrial machinery can be a complex and difficult task. With every advance in machinery design and increased levels of automation, the task becomes more difficult. The dangers and hazards created by these machines can be made safer through the use of Larco Industrial Safety Mat Systems, including the Larco Zone Monitor 3000 control unit.

The information contained in this manual will help with installation and make full use of the Larco Zone Monitor 3000 in combination with Larco safety mats. **This manual should be read in its entirety prior to beginning the installation.**

The Larco Safety Mat and Zone Monitor 3000 control system should not be used as a substitute for machine guarding requirements set forth by local and national organizations, such as OSHA. The installer must be appropriately qualified for the installation task and familiar with the requirements for the particular application, as well as any local codes or ordinances, before attempting to install any safeguarding systems. Proper ESD practices and procedures should be followed during installation to protect against possible electronic damage to the Larco Zone Monitor 3000.

### Zone Monitor 3000 Overview

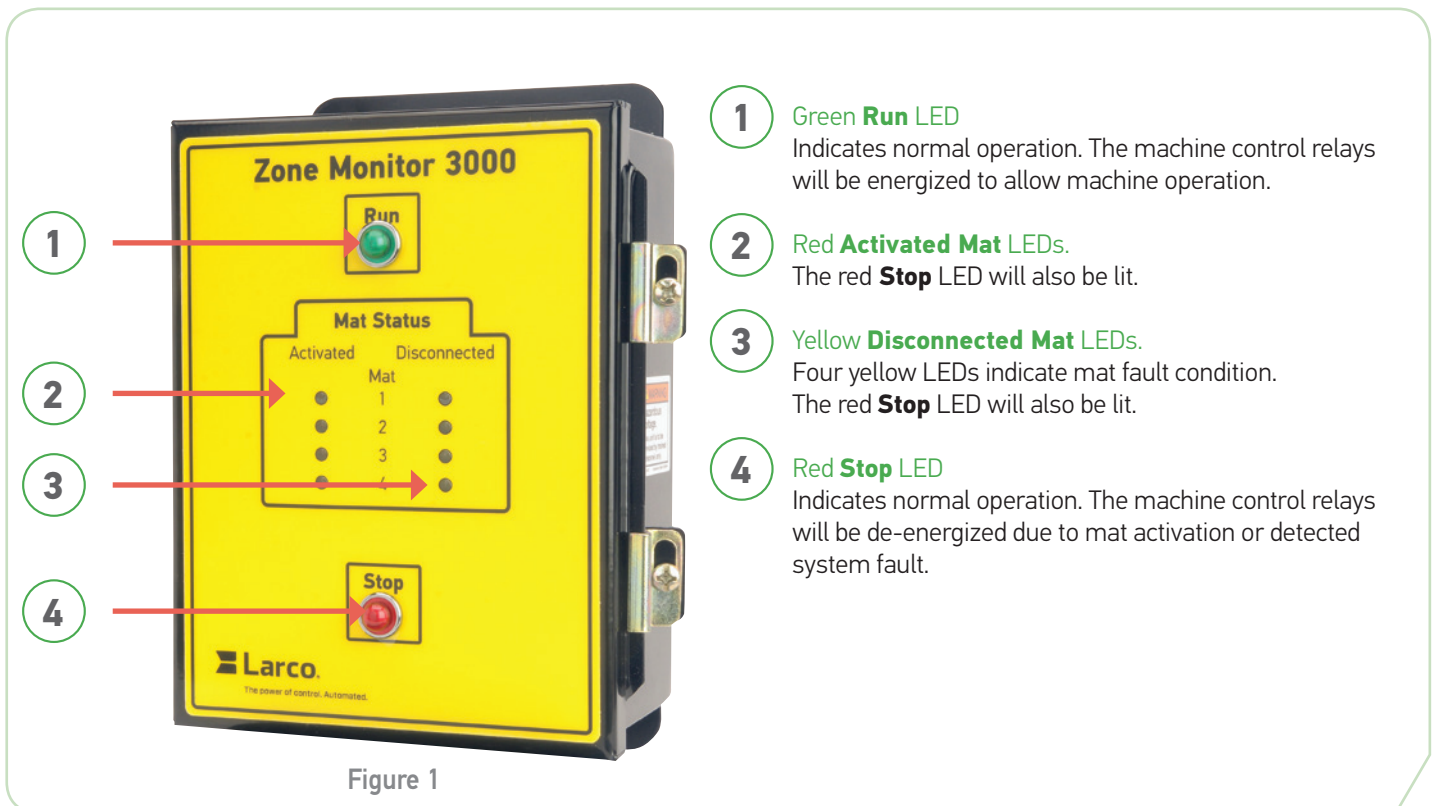

Zone Monitor 3000 Overview

- 5** Redundant Safety Relay Pack  
Removable relay pack allows for easy field replacement.
- 6** Machine Control Connector
- 7** Remote Restart Connector (under the relay pack – see Figure 2 -inset)  
Connection point for remote restart switch option, when applicable.
- 8** Option Jumpers (under relay pack – see Figure 2 -inset) Used for choosing automatic restart or guard only mode of operation.
- 9** Mat Connectors  
Four mat connectors make wiring faster and easier. Optional quick-disconnects available.
- 10** Relay Fault LED  
Used in normal operation to indicate a detected relay fault, or temporary line power drop out.
- 11** Manual Restart Switch  
Momentary contact switch used to restart the Zone Monitor 3000 and/or associated equipment.
- 12** Manual Reset Switch  
Momentary contact switch used to reset the Zone Monitor 3000. Will clear the Relay Fault Latch if fault has been removed.
- 13** Power Connector (under the relay pack – see Figure 2 -inset) For incoming 110/230 VAC or 24 VDC power.
- 14** Earth Ground Lug

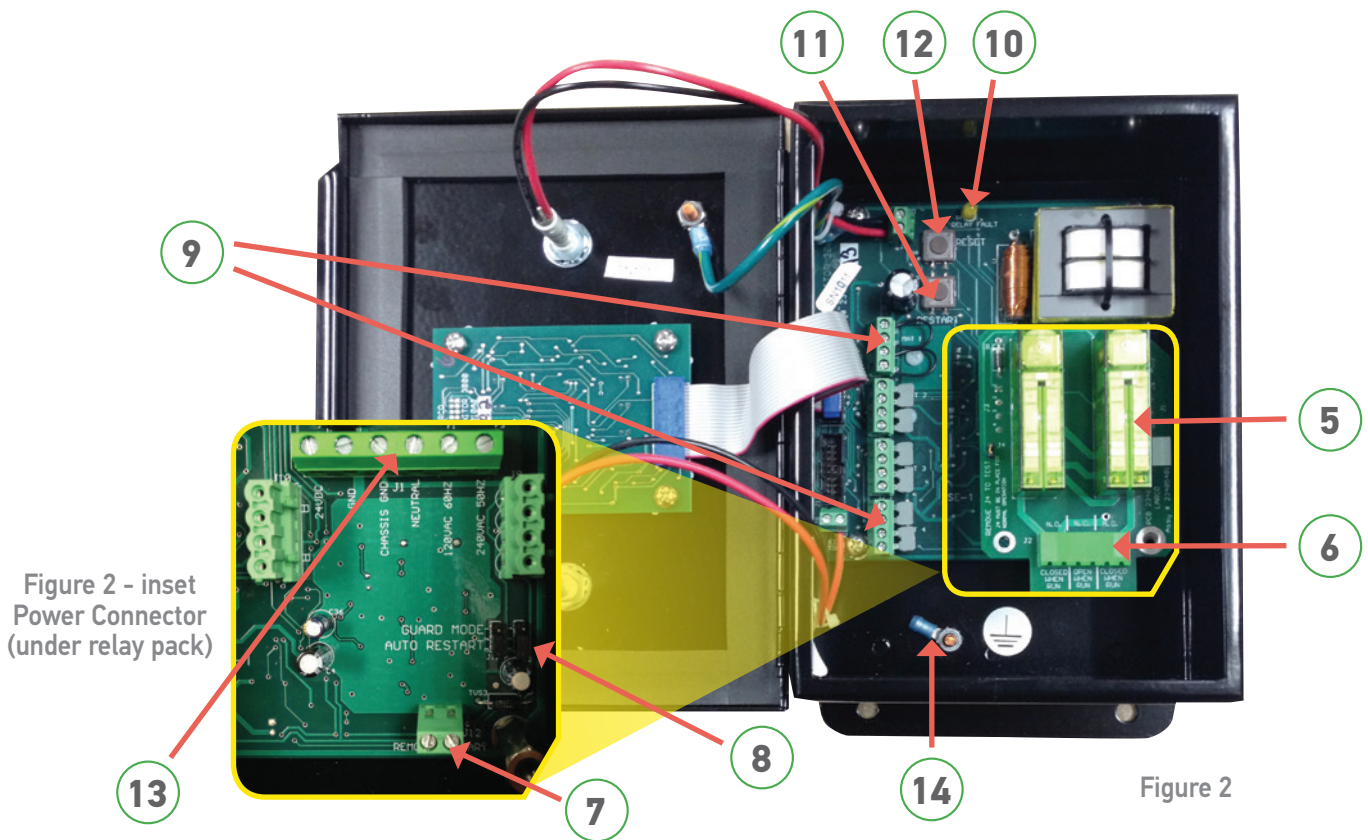

## Zone Monitor Installation Instructions

The Larco Zone Monitor 3000 was designed with safety and convenience in mind. Unpack and become familiar with the unit before installing it.

**WARNING!** Always use proper ESD (Electrostatic Discharge) avoidance practices by wearing the appropriate grounding apparel whenever opening or working inside the Zone Monitor 3000 enclosure.

### 1 Choose the Safety Mat Locations

Refer to the Safety Mat Installation Guide that accompanies the Larco safety mats.

If there is more than one safety mat in the system, it may be helpful to identify and label the mats by number according to the connection point in the Zone Monitor that it will be wired to in step 4. Identification of the mats will allow full advantage of the Zone Monitor 3000 mat diagnostic capabilities.

The Zone Monitor 3000 is designed to operate with Larco's standard mat cord. It is possible to order mats with longer leads to reach the control box, as long as the total length of each mat cord connected does not exceed 40 feet.

### 2 Mount the Zone Monitor

Locate the Zone Monitor outside of the safeguarded space and, whenever possible close enough to the mats to allow all of the mat leads to be routed directly into the control enclosure.

Select a sturdy horizontal or vertical mounting surface that has enough room to allow the cover door to open after installation. The machine operator should be able to view the status lights easily on the face of the control.

Access holes have been provided at the bottom of the enclosure for safety mat wires, incoming power, and control signal wires. If additional holes are required, remove the internal electronics prior to drilling. The circuit board mounted on the inside of the cover should also be removed and reinstalled along with the main board.

Mount the unit using the mounting holes provided on the upper and lower mounting flanges.

### 3 Select Operating Options

Two optional modes of operation are available with the Zone Monitor 3000. They are enabled or disabled by changing option jumpers, which are located on the main board, under the relay module (see Figure 3).

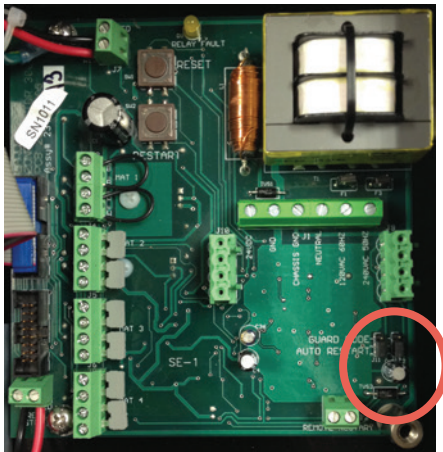

Figure 3 – Option Jumpers

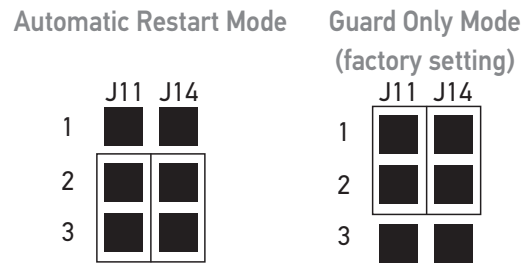

Figure 4 – Option Jumper Selections

**WARNING!** Always ensure the Zone Monitor's power is off before making or changing selections. Power should be removed from the unit, then operating changes completed and power restored.

Refer to Figure 4 to select the desired mode of operation.

- Option 1: **Guard Only Mode** requires pressing the restart switch to resume operation each time the control enters a **Stop** condition or the power is cycled to the Zone Monitor. The Zone Monitor 3000 is shipped from the factory in **Guard Only Mode**.
- Option 2: **Automatic Restart Mode** allows the machine to resume operation immediately once an activated mat is cleared.

**WARNING!** The automatic restart mode of operation should not be used unless the machinery has its own control reliable latching stop circuitry to prevent unexpected restart. Selecting the automatic restart mode of operation will allow the Zone Monitor and associated machinery to automatically restart upon clearing an activated mat.

## 4 Connect the Safety Mats

### a. Prepare the Mat Lead Wires

Remove approximately 1" (25mm) of the outer jacket from the four-wire mat cord, being careful not to cut the insulation on the four individual mat wires.

Next, strip off approximately 3/16" (5mm) of insulation from the ends of the four individual mat wires. If there is more than one safety mat, the installer will want to make sure that each mat lead is labeled to indicate the corresponding mat.

### b. Become Familiar with the Connector Positions

When viewing the four mat connectors, note that the wiring sequence begins with connector number 1 being the highest connector. The sequence travels down, with the lowest connector being number 4. Each position at each mat connector is marked with a **B** for black wires and a **W** for white wires.

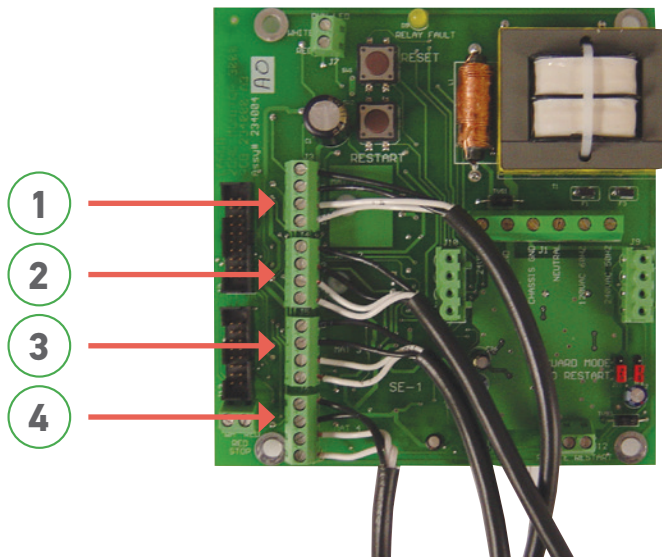

Figure 5 – Mat Connectors with Positions Indicated

### c. Route the Mat Lead Wires

Route the mat lead wires into the control box through watertight conduits and the wiring entry holes, making sure to use watertight fittings to maintain the Type 12/IP65 rating.

### 4 Connect the Safety Mats (cont.)

#### d. Connect Mats

While wiring the mats, use caution not to insert the insulation of the mat wires into the connector by pushing too far in.

Starting with the mat connector at the top left, connect the black mat wires from mat number one into the first and second screw terminals of that connector, and the white wires from mat number one into the third and fourth screw terminals of that connector. (see Figure 5).

If there are additional mats in the system, remove the factory-installed jumpers and make mat connections as done for mat number one. NOTE: Any unused mat connectors must have the jumpers left in them, black must be jumped to black and white to white.

**NOTE:** When wiring the mats, ensure the mat clamps in the terminal blocks are in the fully open position by turning the screws counterclockwise several turns. Once the mat wires in the terminal blocks are secured, gently pull on the mat wire to ensure it is securely and properly installed.

### 5 Connect Optional Remote Restart Switch

In the **Guard Only Mode** of operation, the **Restart** switch is used to re-energize the machine control relays and allow the machinery to operate after the Zone Monitor has changed to a **Stop** condition. A **Remote Restart** switch may be added to the Zone Monitor for ease of use and to avoid entry into the enclosure for each restart. If a switch is added, it must be a normally-open, momentary contact switch with a contact rating of 0.5 A at 24 VDC minimum. Connect the switch to the connector positions marked **Remote Restart** (see Figure 6).

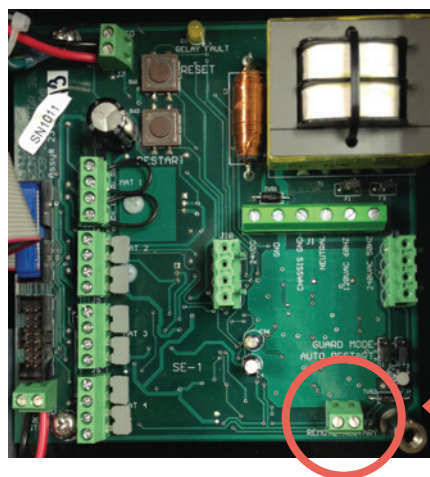

Figure 6 – Remote Restart Connector



**6** Connect Machine to Control Wiring

Two sets of isolated, normally-open contacts and one normally-closed set of contacts are provided for machine control (see Figure 7). Connect to the machine's control as required to maintain proper safety. The contact positions are as follows.

- Position 1 & 2 Normally Open (Closed When Run)
- Position 3 & 4 Normally Closed (Open When Run)
- Position 5 & 6 Normally Open (Closed When Run)

**A Note Regarding Inductive Loads**

Inductive loads from the machine's control circuit can greatly affect the life of the Zone Monitor 3000 machine control relays. An effective and proven method for extending the life of the relays is to use a varistor for surge suppression installed across the inductive load. Size the varistor according to the specific load characteristics. A good general formula for sizing the varistor is to add 20 percent to the maximum voltage.

**WARNING!** Never install a varistor across the machine control contacts of the Zone Monitor 3000. Failure of the varistor to a shorted condition in this position would allow the machinery to continue to operate regardless of the Zone Monitor's output signals.

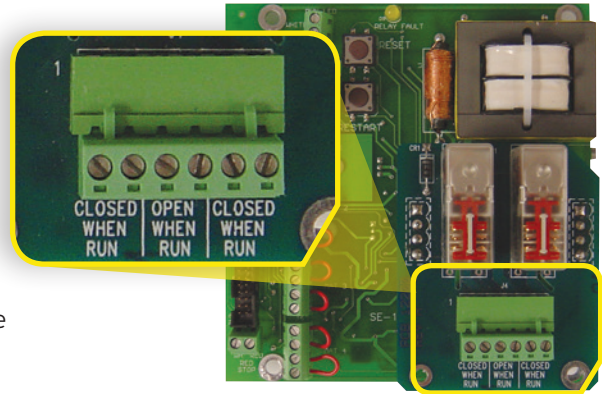

Figure 7 – Machine Control Connector

**7** Connecting Input Power

**Electrical connections must be made by qualified service personnel. The enclosure must be permanently attached to a surface and the wiring must run through water tight conduit as specified below.**

The standard Zone Monitor 3000 can be powered with either 110 VAC, 230 VAC or 24 VDC (see Figure 8).

A minimum of 18 AWG wire should be used to connect the Zone Monitor 3000 to the main power. Use 1/2" (12.7mm) steel or malleable iron liquid-tight conduit and fittings to connect the Zone Monitor 3000 to the main power junction box. This will maintain the Type 12/IP65 rating.

Strip 1/4" (6mm) from the ends of the wires and insert them into the J1 terminal block, under the removable relay module, using the wiring guide in sections 7a, 7c, 7c. Do not tin the ends of the wires. Tighten the terminal block screws until the wires are compressed and cannot be pulled out with a slight tug.

24 VDC                      110/230 VAC  
 Power Connection    Power Connection

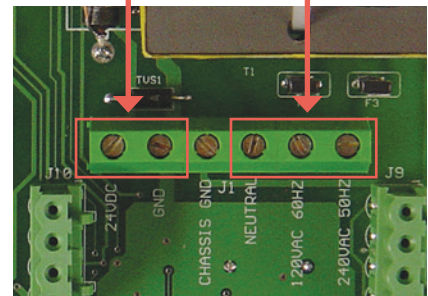

Figure 8 – Input Power Connections (under Relay Module)

## 7 Connecting Input Power (cont.)

### a. 120 VAC Configuration

- Position 1: Not Used
- Position 2: Not Used
- Position 3: Do Not Connect (use earth ground lug)
- Position 4: Neutral
- Position 5: 120 VAC Hot
- Position 6: Not Used

### b. 230 VAC Configuration (J1)

NOTE: 240 VAC is designed for use in Europe. If this power input is used in the U.S., install a fuse in the second 240 V hot line (L2) before hooking it to the neutral input (position 4).

- Position 1: Not Used
- Position 2: Not Used
- Position 3: Do not Connect (use earth ground lug)
- Position 4: Neutral (or L2 hot for U.S. applications if a fuse is added in the line)
- Position 5: Not Used
- Position 6: 240 VAC Hot

### c. 24 VDC Configuration (J19)

- Position 1: 24 VDC
- Position 2: 24 VDC Ground
- Position 3: ESD Ground Protection
- Position 4: Not Used
- Position 5: Not Used
- Position 6: Not Used

### d. Ground Connection

The AC earth ground wire must be connected to the chassis ground stud.

Use a crimping tool specified for use with 14-16 AWG PIDG connectors and follow the manufacturer's instructions for its use.

Strip 5/16" (78mm) from the end of the ground wire and insert it into the supplied terminal lug located on the grounding stud (see Figure 9). Crimp the wire lug so the wire will not slip out. Insert the ground wire lug onto the ground stud over the star washer. Place the nut over the ground lug and tighten the lug securely.

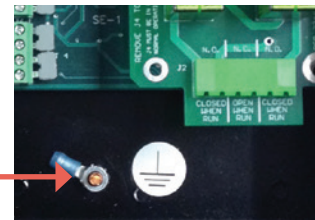

Figure 9 – Earth Ground Lug

## Testing and Using the System

### 1 Use Extreme Caution to Verify Equipment

When the installer begins the verification of equipment, assume that the equipment could start at any moment until system check out and verification is complete.

### 2 Clear the Area

Make sure that all personnel are out of and cannot enter the hazardous area during the testing procedure.

### 3 Become Familiar with the Indicator and Diagnostic Lights

During testing of the system the installer will be asked to observe the lights that are part of the Zone Monitor 3000. All of these lights are on the face of the unit, except for the internally mounted yellow **Relay Fault** LED. Refer to Figures 1 and 2 to become familiar with the location of the lights.

### 4 Check Operation

#### a. Checking Operation in Guard Only Mode

(If **Automatic Restart Mode** of operation was chosen, skip to step 4b.) Make sure that the machinery is not powered and that the machine control wiring connector is unplugged. Apply power to the Zone Monitor 3000 while observing the indicator and diagnostic lights.

1. In the **Guard Only Mode** of operation the red **Stop** LED should turn on.
2. Press and release the **Restart** button and verify the red **Stop** LED turns off and the green **Run** LED turns on. The two machine control relays energize.
3. Remove jumper J4 on the relay board.
4. In the **Guard Only Mode** of operation the red **Stop** and yellow **Relay Fault** LEDs should turn on.
5. Place the jumper J4 on the relay board.
6. Press and release the **Reset** button. The yellow **Relay Fault** LED should turn off.
7. Press and release the **Restart** button and verify the red **Stop** LED turns off and the green **Run** LED turns on. The two machine control relays energize.
8. Next, apply and release pressure to safety mat 1 in the system and verify that the green **Run** LED turns off and the red **Stop** LED turns on. Verify that the appropriate red **Activated Mat** LED for mat number is on. The machine control relays de-energize.
9. Now press and release the **Restart** switch to return to a **Run** condition and check each of the safety mats in the system the same way as was done for mat 1.
10. Next, while in a green **Run** condition, carefully disconnect one of the safety mats by removing one of the mat wires from any of the mat connectors and verify that the unit changes to a **Stop** condition. Verify the **Disconnected** LED of the disconnected mat is on and that the unit remains in a **Stop** condition. Reconnect the mat, press the **Restart** switch and verify that the unit changes to a **Run** condition.

If the unit does not function as described, note the condition of the indicator lights and refer to the troubleshooting guide on page 13.

### 4 Check Operation (cont.)

#### b. Checking Operation in Automatic Restart Mode

Make sure the machinery is not powered and that the control output wiring connector is unplugged. Remove jumper from J4 of the relay module. Apply power to the Zone Monitor 3000. Observe the indicator lights.

1. In the **Automatic Restart Mode** of operation verify that the green **Run** LED turns on.
2. Remove jumper J4 on the relay board.
3. In the **Automatic Restart Mode** of operation the red **Stop** and the yellow **Relay Fault** LEDs should turn on.
4. Place the jumper J4 on the relay board.
5. Press and release the **Reset** button. The yellow **Relay Fault** LED and the red **Stop** LED should both turn off. The green **Run** LED should turn on. The two machine control relays energize.
6. Next, while in the green **Run** condition, apply continuous pressure to safety mat 1 in the system and verify that the green **Run** LED turns off and the red **Stop** LED turns on. Verify that the appropriate red **Activated Mat** LED for mat number 1 is on. Now release the pressure to the safety mat and verify that the unit changes to a green **Run** condition automatically. If there is more than one mat in the system, continue by checking all of the mats in the system in the same way as tested mat 1, noting that the activated mat corresponds to the number of the **Activated Mat** LED that turns on. NOTE: If more than one mat is activated, the mat with the lowest number will be displayed.
7. Next, while in a green **Run** condition, carefully disconnect one of the safety mats by removing one of the mat wires from any of the mat connectors and verify that the unit changes to a red **Stop** condition and the **Disconnected Mat** LED of the mat disconnected is on. Reconnect the mat, and verify that the unit changes to a green **Run** condition automatically.

If the unit does not function as described, note the condition of the indicator lights and refer to the troubleshooting guide on page 13.

#### c. Check the Relay Pack

Remove the relay pack jumper (J4) and verify that the yellow **Relay Fault** LED is on. Replace the jumper and press the **Reset** button. If the unit is in **Guard Only Mode**, press the **Restart** button as well. Verify that the unit returns to a green **Run** condition.

**NOTE: Perform this check monthly.**

#### d. Checking the Machinery

**Use Extreme Caution.** Be aware that with some machinery, sudden stopping and starting could be a hazard in itself. Take every precaution when entering the protected area to activate and test the safety mat system. If all is working as expected, plug the control wiring connector back into the relay pack and apply drive power to the machine. Check that the equipment stops and starts as expected when stepping on and off the safety mats.

### 5 Periodic Checkout Procedure

The functioning of the safety mat monitoring system must be verified periodically to ensure proper operation of the safety relays.

## Troubleshooting Guide

**WARNING!** If diagnosing the installation, be aware that some of the following instructions for clearing fault conditions may cause the machinery to start. Make sure the area is clear of personnel and the machinery is powered down before proceeding with caution.

### Condition: All lights are off

#### Probable Cause:

- No power to the Zone Monitor 3000.
- Poor (loose) connections.
- Relay pack is loose.

#### Solution:

- Test for incoming power.
- Recheck terminal block for screw-clamp tightness and receptacle position.
- Refer to step 7 on page 9 and recheck configuration.
- Check to ensure relay pack is securely seated.

### Condition: Red Stop LED stays on

#### Probable Cause:

- The unit is in **Guard Only Mode** and is waiting for a restart signal.
- A relay fault or intermittent power failure occurred.

#### Solution:

- Refer to installation instructions regarding restart in guard only mode
- Open the case and observe the yellow **Relay Fault** LED. If it is lit, press the **Reset** button, and the **Restart** button if in **Guard Only Mode**, and test one of the mats. If the internal yellow **Relay Fault** LED stays on, or comes back on at any time during this test, replace the relay pack.

### Condition: Internal yellow Relay Fault LED is on

#### Probable Cause:

- Machine control relay pack has failed.
- Temporary line power drop occurred.

#### Solution:

- Press the **Reset** button, and the **Restart** button if in **Guard Only Mode**, and test a mat. If the internal yellow **Relay Fault** LED stays on or comes back on at any time during this test, replace the relay pack.

### Condition: Yellow Mat Disconnected and red Stop LED stays on

#### Probable Cause:

- Broken or intermittent mat wire connection.

#### Solution:

- For mat or mat wire problems, refer to the **Mat Status** LEDs on the front of the unit. The number of the LED that is on corresponds to the disconnected safety mat.

### Condition: Green Run LED stays on but the machine will not operate

#### Probable Cause:

- The machine control relay signal is not reaching the machine control.
- A different device or machine interlock is preventing operation.

#### Solution:

- Check the wiring to the machine from the machine control connector to the machine's control connection point.
- Replace the machine control relays of the Zone Monitor 3000.
- Check for other machine interlocks that may be preventing operation.

## Controller Specifications

DESCRIPTION	PART NUMBER
Response Time	<30 ms
Indicators	<b>Run</b> = Green LED <b>Stop</b> = Red LED <b>Mat Status</b> = 4 Mat Activated Red LEDs and 4 Mat Disconnects Yellow LEDs <b>Relay Fault</b> = Internal Yellow LED
Operational Modes	Selectable <b>Guard Only</b> or <b>Automatic Restart</b>
Power Input	120 VAC (for 60Hz); 240 VAC (for 50Hz) or 24 VDC
Rated Supply Current	0.125A AC, 0.75A DC
Safety Inputs	Removable Connectors for up to Four 4-wire Safety Mats with up to 40' Cord Length Each (quick disconnect mat connections available)
Safety Output Relays	Two Captive Contact Relays with Two Closed when Run (NO) and One Open when Run (NC). Sets of Contacts Rated 8 Amps at 230 VAC
Relay Life	Mechanical 10,000,000 Operations; Electrical 500,000 Operations at 1 Amp at 240 VAC
Operating Temperature	32°F - 122°F
Relative Humidity	20-90% Acceptable Range
Restart Function	Selectable Manual or Automatic Restart; Internal/Lockout Restart and External/Remote Restart Available
Reset Function	Power-up/Relay Fault Reset Internal Manual Push Button
Enclosure	Steel, Powder Coat, 8" h x 6" w x 3.75" d
Enclosure Rating	Type 12, IP65
Mounting	Surface Mount
Shipping Weight	9 lbs

Details and Dimensions

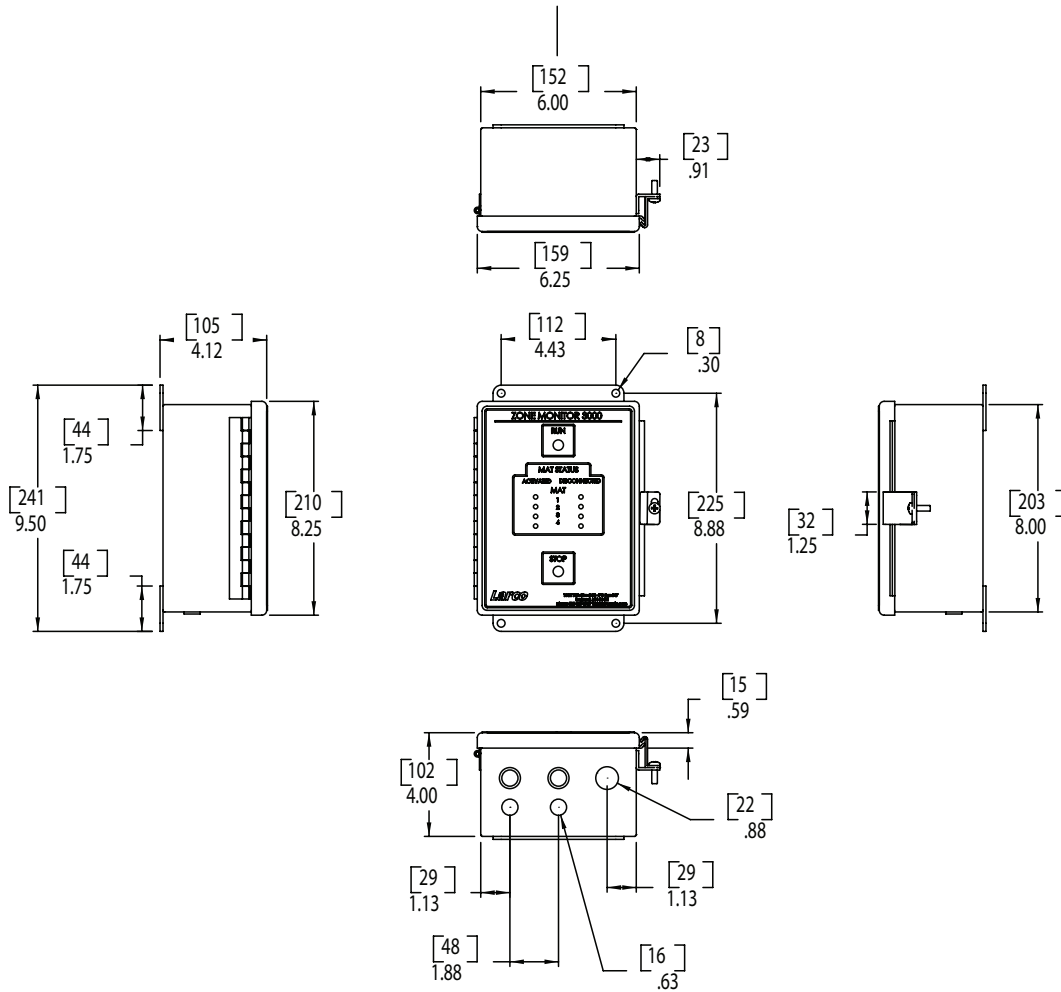

Dimensions in inches, (mm)

**Warning!** Usage of safety mats and safety mat devices is governed by each user's local codes and applicable industry standards. Improper usage of these devices could result in severe injuries. Applications must be limited to machines that can be stopped consistently. In the event that Larco Safety Mats do not prevent all access to the hazardous operation, the unprotected access must be guarded by other appropriate safeguarding devices or barriers.

For more information on Larco Industrial Safety products and accessories, visit [www.larco.com](http://www.larco.com).



The power of control. Automated.

## Industrial Safety Products Zone Monitor 3000 Installation and Operation

223-0120-000 Rev. C 5/19



WARNING: Cancer and Reproductive Harm - [www.P65Warnings.ca.gov](http://www.P65Warnings.ca.gov)

ATEK Access Technologies  
10025 Valley View Road, Ste. 190  
Eden Prairie, MN 55344 U.S.A.

PH: 1.800.523.6996  
FAX: 1.800.589.3705  
+1.218.829.9797

[www.atekaccess.com](http://www.atekaccess.com)



Access the power of technology.

©2019 ATEK Access Technologies, LLC. All Rights Reserved. Larco images and marketing materials are protected by various patents, copyrights and/or trademarks. ATEK assumes no responsibility for any errors which may appear in this document, reserves the right to change devices or specifications detailed herein at any time without notice, and does not make any commitment to update the information contained herein. No licenses to patents or other intellectual property of ATEK are granted by the Company in connection with the sale of Larco products, expressly or by implication.