

433 MHz Vestibule Sequencer Installation Instructions



The power of control. Automated.

The Larco ultra-small vestibule sequencer and transmitters operate at 433.92 MHz and provides a method for operating multiple automatic doors from a single transmitter with a user-defined, delayed opening signal to the second door via a second sequencer unit. The delay of the second door's opening helps minimize heating and cooling loss by allowing the first door to close, or begin to close before the second door opens.

NOTE: Read this guide in its entirety before installing any Larco transmitter or sequencer. It is important to complete the programming procedure before installing the vestibule sequencer in its final location. The installer must have access to the vestibule sequencer's programming button and must be able to view the vestibule sequencer's LED (Light Emitting Diode) during the programming process.

CAUTION: As the programming and installation procedures are completed, the door may open or close if power is applied. Also, the installer must be appropriately qualified for the installation and familiar with the requirements for the installation as well as any local codes or ordinances before attempting to install automatic door control devices.

Installation

Follow the installation instructions below for each vestibule sequencer in the installation. Each door control will require a separate vestibule sequencer unit.

1 Mount the vestibule sequencer in a location so that the antenna is not surrounded by metal. Metal attenuates RF signals causing a reduction in range and inconsistency of signal reception. Door operator motors and controls may also cause RF interference. Locate the vestibule sequencer away from the door control's motor and power supply. If the vestibule sequencer is mounted in a metal enclosure, drill a hole in the enclosure and thread as much of the antenna as possible through the hole. This reduces the effects the metal enclosure will have on the vestibule sequencer's reception.

2 The vestibule sequencer comes equipped with a wiring harness for easy installation. Reference the wiring diagram (Diagram 2) on the right side of page for proper connections. The vestibule sequencer must be connected to the power source before programming, but it is not necessary to connect the relay output wires at this time. Connect these wires as the last step as a safety precaution to keep the doors from operating during the installation. Remove the power source after the programming procedure as a safety precaution. The vestibule sequencer is designed to retain its programming even after power has been removed.

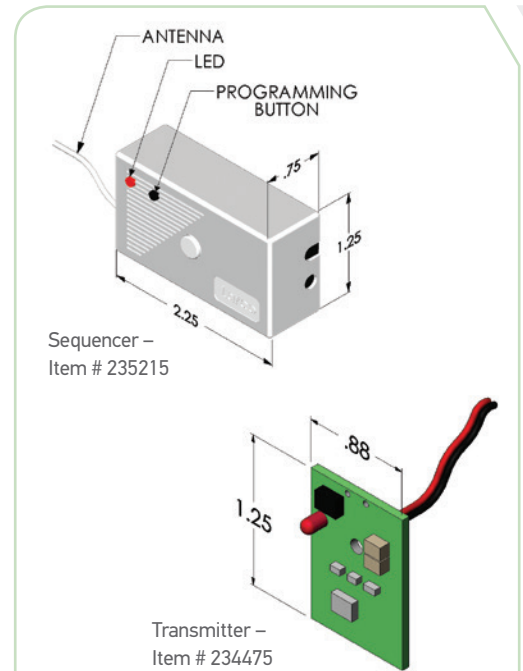

Diagram 1: Vestibule Sequencer and Transmitter Dimensions

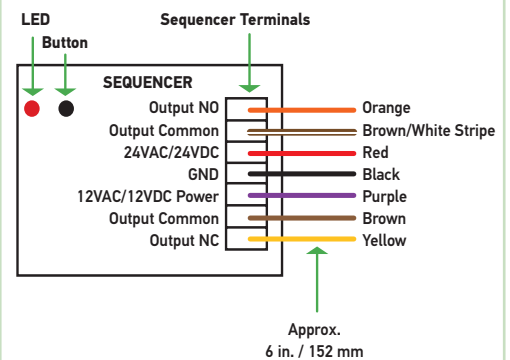

Diagram 2: Vestibule Sequencer Wiring Harness

- Orange:** Relay Output – Normally Open
- Brown with White Stripe:** Relay Output – Common
- Red:** 24VAC/24VDC Power
- Black:** Ground
- Purple :** 12VAC/12VDC Power
- Brown:** Relay Output – Common
- Yellow:** Relay Output – Normally Closed

433 MHz Vestibule Sequencer

Installation Instructions



The power of control. Automated.

Programming Procedures

Follow the appropriate set of instructions below to program each vestibule sequencer in the installation.

NOTE: The vestibule sequencer's single programming LED changes color (green or red) and either glows steadily or flashes to indicate various programming operations. Before beginning the programming procedure, check to see that the sequencer's LED glows red, indicating that power is connected.

- 1 Program the vestibule sequencers to pair with the transmitter.**

Repeat these steps for each vestibule sequencer and transmitter pair.

 - A. Press and release the programming button on the vestibule sequencer. The LED will change from red to solid green. This indicates that it is ready to learn the transmitter signal.
 - B. Press and release the transmitter button and confirm that the vestibule sequencer's LED changes from green to red. This indicates that it is learning the signal from the transmitter.
 - C. After 3 seconds, press and release the transmitter button again and confirm that the vestibule sequencer's LED flashes green several times. This indicates the end of the learning procedure. When complete, the LED will change to solid red.

- 2 Program the vestibule sequencer's time delay for signaling the door to open.**

Repeat these steps for each vestibule sequencer and transmitter pair requiring a timed delay before activating a door's operation. NOTE: In a typical two-door application there will be no time delay in the signal to open the first door.

 - A. Press and hold the programming button on the vestibule sequencer connected to the second door for 6 seconds and release. Confirm that the LED is solid red. This indicates that it is ready to learn the time delay.
 - B. Press and release the transmitter and confirm that the vestibule sequencer's LED changes to solid green. This indicates that it is waiting for a second signal after the desired amount of time has elapsed.
 - C. When the desired amount of time has elapsed (up to 4 hours), press the transmitter again and confirm that the LED flashes green several times. This indicates the end of the learning procedure. When the procedure is complete the LED should change back to solid red.
 - D. In a two-way traffic application, there would typically be two transmitters (wall switches) – one for egress and one for ingress. The Larco vestibule sequencer will recognize when to delay the opening depending on the unique signal from the individual transmitters. In this application, repeat step 2 in the opposite traffic direction.

- 3 Test the system to confirm the operation.**
 - A. Press the transmitter and walk-test the installation to confirm that the time delay programmed is appropriate for the application. The first door should begin its opening and closing sequence immediately upon activation of the transmitter. The second door should begin its sequence after the chosen time delay.
 - B. If the time delay requires changing, simply repeat the instructions in step 2.

Deleting Programming Procedures

To clear the sequencer of all previously learned transmitters, press the sequencer's programming button for more than 8 seconds until the sequencer's LED starts blinking green. Release the programming button. The LED should now be solid red. The sequencer's memory is now cleared.

The sequencer and transmitter comply with FCC part 15/15.231, Industry Canada RSS-210, EN55022A, EN55024, EN300-220-3, and EN301-489-1. Operation is subject to the following two conditions: (1) This device may not cause harmful interference, and (2) this device must accept any interference received, including interference that may cause undesired operation. This product may be susceptible to local transmissions being generated near the transmitter's fundamental frequency. Testing has shown some susceptibility in a frequency range of 416-440 MHz.



223-0128-000 Rev. E 8/21



WARNING: Cancer and Reproductive Harm - www.P65Warnings.ca.gov

ATEK Access Technologies
10025 Valley View Road, Ste. 190
Eden Prairie, MN 55344 U.S.A.

PH: 1.800.523.6996
FAX: 1.800.589.3705
+1.218.829.9797

www.atekaccess.com



Access the power of technology.