

## Loading Docks

# Larco CAS Keeps Docks Secure AND Efficient

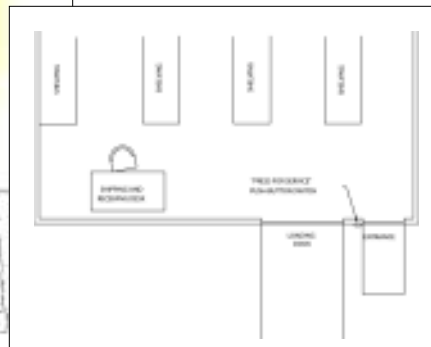

*In today's high-security environment, businesses keep loading docks secure by locking pedestrian access doors. This makes it difficult for employees to work efficiently in other areas of your store or warehouse and still respond when someone on the dock needs assistance. The Larco Customer Awareness System solves this problem by providing employees a simple, discreet and effective method for monitoring loading docks, improving efficiency while keeping your business secure.*



- Enables employees to work efficiently in other areas of your business while monitoring the loading dock.
- Less expensive than other systems on the market that provide annoying audible signals
- Discreet pager system hides everything but quick, responsive service to those needing assistance
- Available with either a rugged, weather resistant sensing mat or wall-mounted switch
- Enables employees to monitor up to three separate loading dock zones with one pager.

*HOW IT WORKS. In a loading dock application like the one pictured above, a mat is placed on the loading dock or a switch is mounted on the wall (as in the illustration above). The mat automatically senses a person standing on the dock and sends a signal to a transmitter unit hidden from view. Similarly when a person needs assistance, they press the wall-mounted "press for service" switch, which also sends a signal to the transmitter. The transmitter (as illustrated in the diagram at right) sends a signal to a pager worn by loading dock personnel working in other areas, immediately notifying them they're needed at the dock. The entire process takes seconds, but the service provided leaves a lasting impression.*

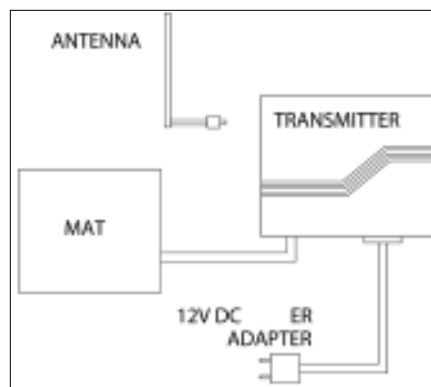

**For More Information,  
Call 800-523-6996  
or visit  
[www.larcomfg.com](http://www.larcomfg.com)!**