

Zone Monitor 5000ex

Installation and Operating Instructions



1902 13th Street S.E.
P.O. Box 547
Brainerd, MN 56401

phone 218-829-9797
toll free phone 800-523-6996
fax 218-829-0139
toll free fax 800-589-3705
www.larcomfg.com

Contents

Section 1—Important Safety Message	page 1
Section 2—Zone Monitor 5000ex Overview	page 1
Section 3—Installation & Operation Instructions	page 3
Appendix A—Glossary	page 11
Appendix B—Dimensional Drawing & Specifications	page 13
Appendix C—Guide to Diagnostic Lights	page 14
Appendix D—Troubleshooting	page 15

Section 1

Important Safety Message

Minimizing the hazards surrounding heavy automated equipment and industrial machinery can be a complex and difficult task. With every advance in machinery design and increased levels of automation, the task becomes more difficult. The dangers and hazards created by these machines can be made safer through the use of Larco Industrial Safety Mat Systems, including the Zone Monitor 5000ex control unit.

The information contained in this manual will help you install and make full use of the Larco Zone Monitor 5000ex in combination with Larco safety mats. **This manual should be read in its entirety prior to beginning the installation.**

The Larco Safety Mat and Zone Monitor 5000ex control system are not to be used as a substitute for machine guarding requirements set forth by local and national organizations such as O.S.H.A. You must be appropriately qualified for the installation task and familiar with the requirements for your particular application as well as any local codes or ordinances before attempting to install any safeguarding systems. Proper ESD practices and procedures should be followed during installation to protect against possible electronic damage to the Zone Monitor 5000ex.

Section 2

Zone Monitor 5000ex Overview

(Refer to figures 1 and 2 on page 2)

- 1. Redundant Safety Relay Pack**
Removable relays allow for easy replacement should they ever wear out.
- 2. Machine Control Connector**
Removable connector makes wiring to your machine control circuit easier.
- 3. External Control and Feedback Connector**
Connection point for MPCE monitoring and remote restart switch when applicable.
- 4. Option Slide Pin Connectors**
Used in conjunction with option selection switches (Feature 7) for enabling or disabling various control functions.
- 5. Mat Connectors (10)**
Ten removable connectors make mat wiring faster and easier.
- 6. End Mat Connector**
Pre-wired connection point for completing the mat safety circuit.
- 7. Option Selection Switches**
Used in conjunction with the option slide pin connectors (feature number 4) for enabling or disabling various control functions.
- 8. System Diagnostic LED**
Used in normal operation and for troubleshooting to indicate a variety of conditions.
- 9. Last Mat Connector**
Special Mat Connector factory pre-wired for easy mat installation.
- 10. Manual Alarm Reset Switch**
Momentary contact switch used to clear a "Fault" condition.
- 11. Manual Restart Switch**
Momentary contact switch used to restart the Zone Monitor 5000ex and/or associated equipment.

Figure 1

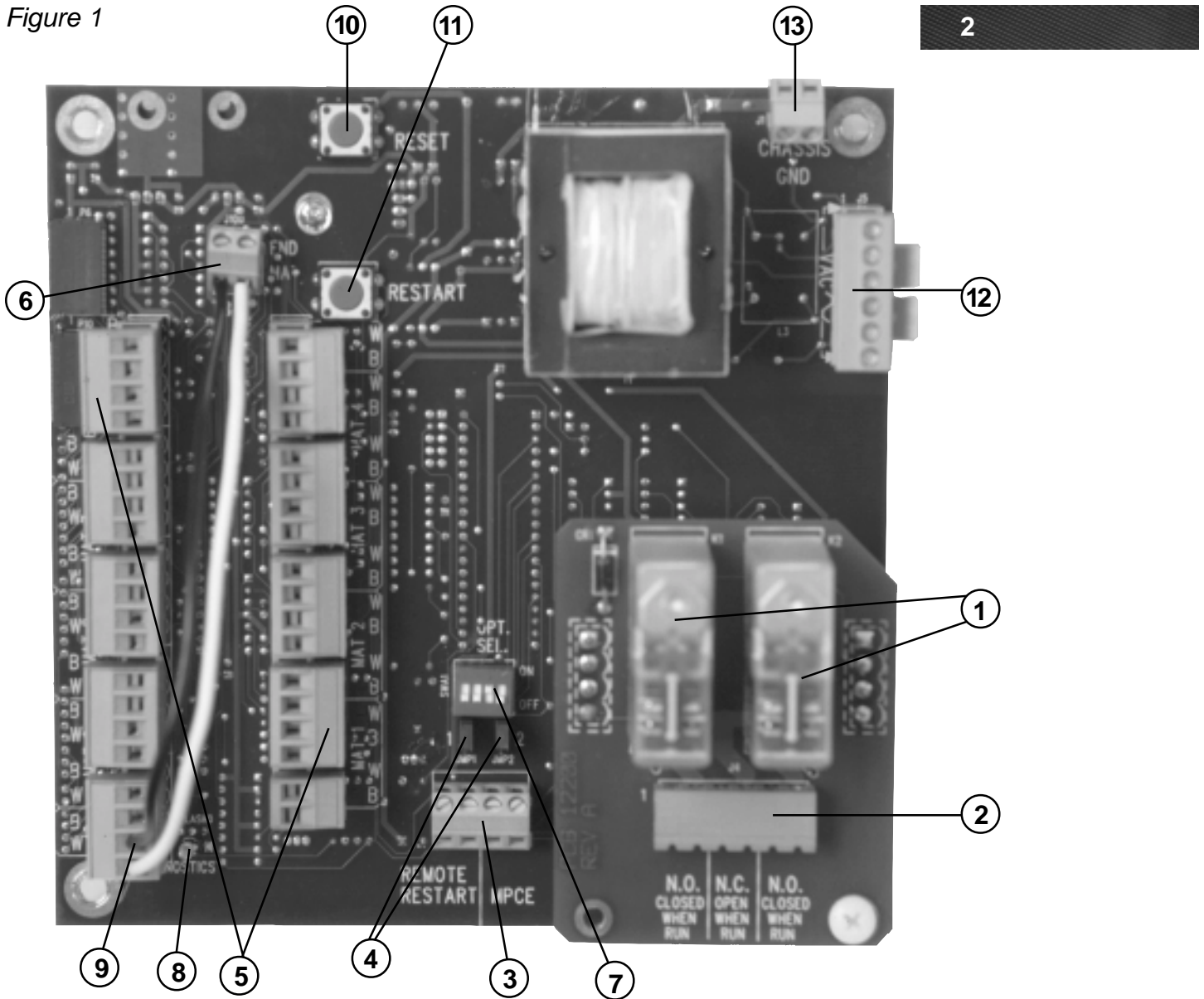

Figure 2



12. Power Connector

Removable connector eases the task of wiring for incoming AC power.

13. Ground Connector

Connection point for grounding.

14. Mat Diagnostic LEDs

Ten red LEDs used to indicate status of Larco mats.

15. Green "Run" LED

Indicates normal operation. The machine control relays will be energized to allow machine operation.

16. Red "Stop" LED

Indicates normal operation. The machine control relays will be de-energized due to mat activation or detected system fault.

17. Yellow "Fault" LED

Indicates fault condition due to detected system fault or improper MPCE feedback signals (when used). The red "Stop" LED will also be on.

Section 3

Installation & Operation Instructions

The Larco Zone Monitor 5000ex was designed with your safety and convenience in mind. Please unpack and familiarize yourself with the unit before installing it. Installation and use of the system will be much easier with a little bit of planning.

WARNING! Always use proper ESD (Electrostatic Discharge) avoidance practices by wearing the appropriate grounding apparel whenever opening or working inside the Zone Monitor 5000ex enclosure.

Step 1

Choose Your Safety Mat Locations

Refer to the safety mat installation guidelines that accompany your Larco safety mats.

If there is more than one safety mat in your system, it may be helpful to identify and label your mats by number according to the connection point in your Zone Monitor that it will be wired to in Step 4. By identifying your mats, you will be able to take full advantage of the Zone Monitor 5000ex's mat diagnostic capabilities.

The Zone Monitor 5000ex is designed to operate with Larco's standard mat wire. It is permissible to extend mat leads to reach the control box as long as the total combined length of all mat leads connected to the monitor **does not exceed 325 feet**.

WARNING!!! Never exceed a total combined mat wire length of 325 feet.

Step 2

Choose the Control Location and Mount the Unit

Locate the control outside of the safeguarded space, and, whenever possible, close enough to the mats to allow all of the mat leads to be routed directly into the control enclosure.

Select a sturdy horizontal or vertical mounting surface that has enough room to allow the cover door to open after installation. The operator should be able to view the status lights easily on the face of the control.

Four access holes have been provided at the bottom of the enclosure for safety mat wires, incoming power and control signal wires.

If both high and low voltage wiring will be entering the unit, run them in through separate conduits.

If additional holes are required, the internal electronics must be protected by removing them prior to drilling. The circuit board mounted on the inside of the cover is permanently attached to the main circuit board and must be removed and re-installed along with the main board.

Mount the unit using the mounting holes provided on the upper and lower mounting flange.

Step 3
Select Operating Options

Several optional modes of operation are available with the Zone Monitor 5000ex. They are enabled or disabled by changing option selection switches and slide pin connectors. Option selection switches and slide pin connectors must correspond correctly or the unit will signal a fault condition at power up. Please note that the up position turns the option selector switches on and that switch number 3 is not used and should always be left on.

Figure 3

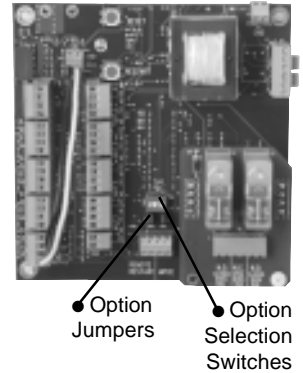

Always ensure your Zone Monitor's power is off before making or changing selections. Changes in the operating options made with power applied to the Zone Monitor will not take effect. Power should be removed from the unit, then operating changes completed and power can be restored.

Refer to Figure 4 to select your desired mode of operation:

A) "Guard Only Mode" requires pressing the restart switch to resume operation each time the control enters a stop condition. When not in guard only mode, the unit is in automatic restart mode.

Figure 4

Guard Only with MPCE Monitoring																				
Option Switches	Option Slide Pin Connectors																			
<table border="1"> <tr> <td></td> <td>1</td> <td>2</td> <td>3</td> <td>4</td> </tr> <tr> <td>ON</td> <td></td> <td></td> <td>X</td> <td></td> </tr> <tr> <td>OFF</td> <td>X</td> <td>X</td> <td></td> <td>X</td> </tr> </table> <p>Switch Positions 3-ON Switch Position 1, 2, and 4-OFF</p>		1	2	3	4	ON			X		OFF	X	X		X	<table border="1"> <tr> <td><input type="checkbox"/></td> <td><input type="checkbox"/></td> </tr> <tr> <td><input checked="" type="checkbox"/></td> <td><input checked="" type="checkbox"/></td> </tr> </table> <p>Jumper J1-OFF Jumper J2-OFF</p>	<input type="checkbox"/>	<input type="checkbox"/>	<input checked="" type="checkbox"/>	<input checked="" type="checkbox"/>
	1	2	3	4																
ON			X																	
OFF	X	X		X																
<input type="checkbox"/>	<input type="checkbox"/>																			
<input checked="" type="checkbox"/>	<input checked="" type="checkbox"/>																			

B) "Automatic Restart Mode" allows the machine to resume operation immediately once an activated mat is cleared. When not in automatic restart mode, the unit is in guard only mode.

Guard Only without MPCE Monitoring																				
Option Switches	Option Slide Pin Connectors																			
<table border="1"> <tr> <td></td> <td>1</td> <td>2</td> <td>3</td> <td>4</td> </tr> <tr> <td>ON</td> <td>X</td> <td></td> <td>X</td> <td>X</td> </tr> <tr> <td>OFF</td> <td></td> <td>X</td> <td></td> <td></td> </tr> </table> <p>Switch Positions 1, 3 and 4-ON Switch Position 2-OFF</p>		1	2	3	4	ON	X		X	X	OFF		X			<table border="1"> <tr> <td><input type="checkbox"/></td> <td><input checked="" type="checkbox"/></td> </tr> <tr> <td><input checked="" type="checkbox"/></td> <td><input checked="" type="checkbox"/></td> </tr> </table> <p>Connector J1-OFF Connector J2-ON</p>	<input type="checkbox"/>	<input checked="" type="checkbox"/>	<input checked="" type="checkbox"/>	<input checked="" type="checkbox"/>
	1	2	3	4																
ON	X		X	X																
OFF		X																		
<input type="checkbox"/>	<input checked="" type="checkbox"/>																			
<input checked="" type="checkbox"/>	<input checked="" type="checkbox"/>																			

C) "MPCE Monitoring" requires proper feedback from your machine's control to allow resumption of operation. Disabling MPCE monitoring eliminates machine control checking.

Automatic Restart with MPCE Monitoring																				
Option Switches	Option Slide Pin Connectors																			
<table border="1"> <tr> <td></td> <td>1</td> <td>2</td> <td>3</td> <td>4</td> </tr> <tr> <td>ON</td> <td>X</td> <td>X</td> <td>X</td> <td></td> </tr> <tr> <td>OFF</td> <td></td> <td></td> <td></td> <td>X</td> </tr> </table> <p>Switch Positions 1, 2 and 3-ON Switch Position 4-OFF</p>		1	2	3	4	ON	X	X	X		OFF				X	<table border="1"> <tr> <td><input checked="" type="checkbox"/></td> <td><input type="checkbox"/></td> </tr> <tr> <td><input checked="" type="checkbox"/></td> <td><input checked="" type="checkbox"/></td> </tr> </table> <p>Connector J1-ON Connector J2-OFF</p>	<input checked="" type="checkbox"/>	<input type="checkbox"/>	<input checked="" type="checkbox"/>	<input checked="" type="checkbox"/>
	1	2	3	4																
ON	X	X	X																	
OFF				X																
<input checked="" type="checkbox"/>	<input type="checkbox"/>																			
<input checked="" type="checkbox"/>	<input checked="" type="checkbox"/>																			

The Zone Monitor 5000ex is shipped from the factory in guard only mode with MPCE monitoring enabled.

Automatic Restart without MPCE Monitoring																				
Option Switches	Option Slide Pin Connectors																			
<table border="1"> <tr> <td></td> <td>1</td> <td>2</td> <td>3</td> <td>4</td> </tr> <tr> <td>ON</td> <td>X</td> <td>X</td> <td>X</td> <td>X</td> </tr> <tr> <td>OFF</td> <td></td> <td></td> <td></td> <td></td> </tr> </table> <p>Switch Positions 1, 2, 3 and 4-ON</p>		1	2	3	4	ON	X	X	X	X	OFF					<table border="1"> <tr> <td><input checked="" type="checkbox"/></td> <td><input checked="" type="checkbox"/></td> </tr> <tr> <td><input checked="" type="checkbox"/></td> <td><input checked="" type="checkbox"/></td> </tr> </table> <p>Connector J1-ON Connector J2-ON</p>	<input checked="" type="checkbox"/>	<input checked="" type="checkbox"/>	<input checked="" type="checkbox"/>	<input checked="" type="checkbox"/>
	1	2	3	4																
ON	X	X	X	X																
OFF																				
<input checked="" type="checkbox"/>	<input checked="" type="checkbox"/>																			
<input checked="" type="checkbox"/>	<input checked="" type="checkbox"/>																			

WARNING!!! Selecting the automatic restart mode of operation will allow the Zone Monitor and associated machinery to automatically restart upon clearing an activated mat.

Step 4 Connect the Safety Mats

4A) Prepare the Mat lead wires

Remove approximately 1" of the outer jacket of the four-wire cord, being careful not to cut the insulation on the four individual mat wires.

Next, strip off approximately 3/16" of insulation from the ends of the four individual mat wires. If there is more than one safety mat, you will want to make sure that each mat lead is labeled to indicate the corresponding mat.

4B) Familiarize yourself with the Connector Positions

Refer to Figure 5 and note that each position of each mat connector is marked with a "B" for black wires or a "W" for white wires. Brackets indicating the position of each of the four mat leads also are printed in the circuit board.

As you view the 10 mat connectors, note that the wiring sequence begins with connector Number 1 being the lower-most, two-position connector on the right side and mat 10 being the lower most 4-position connector on the left side. See Figure 5. The sequence then travels upward and jumps over to the upper most connector on the left side. The sequence then travels downward, with the last connector being the lower most connector on the left side. This arrangement intentionally forces the sharing of connectors between mat leads. The four wires of a given mat will never be attached to a single connector.

Figure 5: 6-Mat Sample Installation

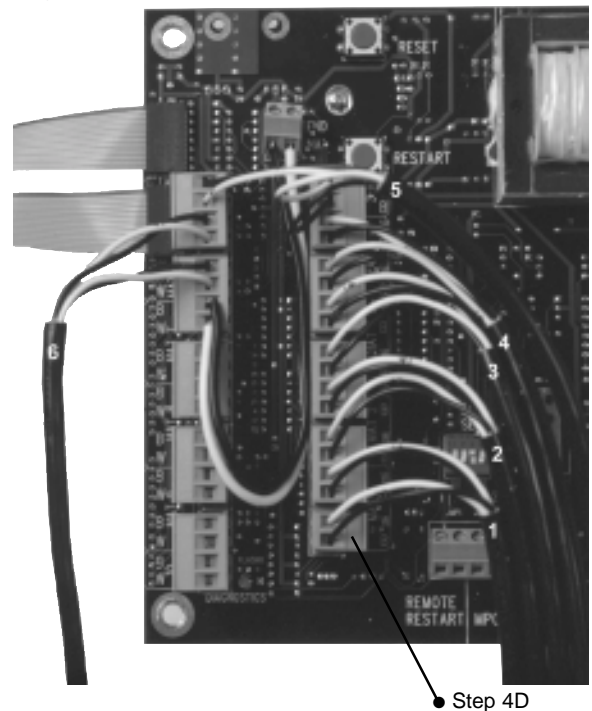

4C) Route the Mat Lead Wires

Route the mat wires into the control box through conduits and the wiring entry holes.

4D) Connect All but the Last Mat

While wiring the mats, use caution not to insert the insulation of the mats wire into the connector by pushing it in too far.

Starting with the two-position mat connector on the lower right side, connect a black mat wire from mat number one in position number one and a white wire from mat number one in position number two (See Figure 5).

Moving upwards to the next connector in sequence, connect the remaining black wire from mat number one into the first position of the connector, and the remaining white wire of mat number one in the second position of the connector.

Moving on to mat number two, continue this sequence of alternating black and white wires until you reach the last mat.

4E) Connect the Last Mat

If less than 10 mats are installed, the final two positions of the last mat connector used must be wired to the end mat connection point. The Zone Monitor was shipped from the factory with the last mat connector pre-wired to the end mat connection point. Move this connector to your last mat position.

If you are installing 10 mats, remove the factory wiring from the end mat connection point, unplug the four-position mat plug connected to these wires and discard it. Use the spare four-position mat connector supplied with the unit.

Following the sequence printed on the circuit board, install the remaining black and white wires from mat number 9 and the first black and white wires from mat number 10. Connect the remaining black and white wires from mat number 10 directly to the end mat connection point.

**Step 5
Connecting Control Input Wiring**

5A) Remote Restart Switch

Unless you have chosen the automatic restart mode of operation, the restart switch is used to re-energize the machine control relays and allow the machinery to operate after the Zone Monitor has changed to a stop condition. A remotely located restart switch may be added for ease of use and to avoid entry into the Zone Monitor enclosure for each restart. If a switch is added, it must be a normally open, momentary contact switch with a contact rating of 0.5A at 24VDC minimum.

Connect the switch to the connector positions marked “remote restart” of the external control and feedback connector. This input is parallel with the board-mounted restart switch so that either switch may be used.

Figure 6

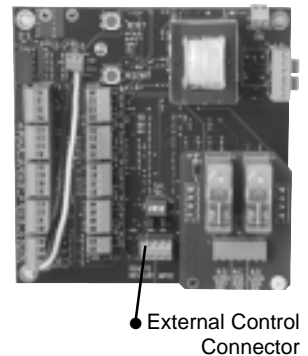

5B) MPCE Monitoring

Unless you have chosen to disable MPCE monitoring, the Zone Monitor will require a normally closed (open when run), dry-contact feedback signal from your control equipment within 200 milliseconds of the Zone Monitor changing to a stop condition. If this signal is not received with MPCE monitoring enabled, the Zone Monitor will change to a “Fault” condition.

Connect this input to connector positions marked “MPCE” of the external control and feedback connector. The input is internally biased with pull up resistors to 12VDC @ 10mA nominal.

Figure 7

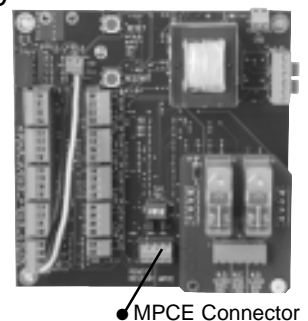

Step 6 Connect Machine to Control Wiring

Figure 8

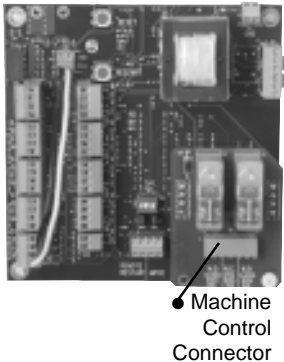

Two sets of isolated, normally-open contacts and one normally-closed set of contacts are provided for machine control. Connect to your machine's control as required to maintain proper safety. The contact positions are as follows:

Position 1 & 2	Normally Open	(Closed when Run)
Position 3 & 4	Normally Closed	(Open when Run)
Position 5 & 6	Normally Open	(Closed when Run)

A note regarding Inductive Loads

Inductive loads from your machine's control circuit can greatly affect the life of your Zone Monitor 5000ex's machine control relays. An effective and proven method for extending the life of the relays is to use a varistor for surge suppression installed across the inductive load.

Size the varistor according to your specific load characteristics. A good general formula for sizing the varistor is to add 20% to your maximum voltage.

For more information on varistors and arc suppression devices, request Technical Bulletin-2.

WARNING!!! Never install a varistor across the machine control contacts of the Zone Monitor 5000ex. Failure of the varistor to a shorted condition in this position would allow the machinery to continue to operate regardless of the Zone Monitor's output signals.

Step 7 Connecting Input Power

The standard Zone Monitor 5000ex (Part Number 0023161100) can be powered with either 115VAC or 230VAC. The unit is shipped from the factory configured for 115VAC input power with the appropriate jumpers already installed.

Figure 9

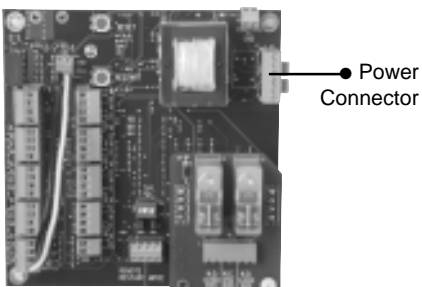

7A) 115VAC Configuration

Position number 1	115VAC Hot
Position numbers 2 & 3	Shorted with jumper
Position numbers 4 & 5	Shorted with jumper
Position number 6	115VAC Return

7B) 230VAC Configuration

Position number 1	230VAC Hot
Position number 2	Not used
Position numbers 3 & 4	Shorted with jumper
Position number 5	Not used
Position number 6	230VAC Return

7C) Ground Connection

Connect the ground wire to either of the two terminals provided.

7D) Optional 24VDC Input Power

A special Zone Monitor 5000ex designed to accept input power of 24VDC is available. The part number for this unit is 2023161100. This unit incorporates an optional relay board that contains the 24 volt input power connections, the machine control relays and the control connections. All other connections and functions are the same as the standard unit.

**Step 8
Testing & Using the System**

8A) Use Extreme Caution!!!

You are about to find out if the system and associated machinery act as you expect them to. Until system check out and verification is complete, assume that the equipment could start at any moment.

8B) Clear the Area

Make sure that all personnel are out of and cannot enter the hazardous area during the testing procedure.

8C) Familiarize yourself with the Indicator and Diagnostic Lights

During testing of the system you will be asked to observe the lights that are part of the Zone Monitor 5000ex. All of these lights are on the face of the unit, except for the internally mounted “system diagnostics” LED. Refer to Figures 10 and 11 to familiarize yourself with the location of the lights. You may also find it helpful to have an observer assist you in the testing process.

Figure 10

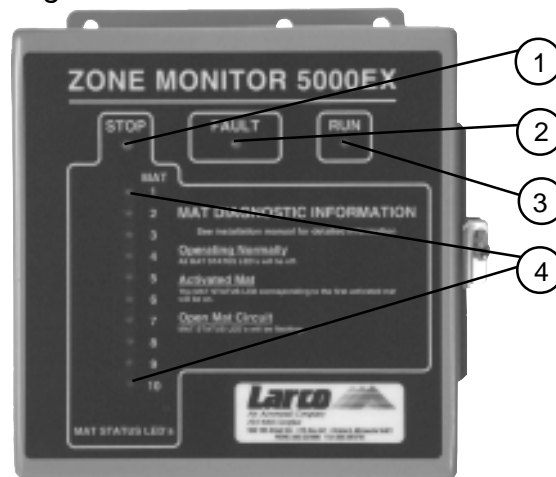

- 1. Red “Stop” LED
- 2. Yellow “Fault” LED
- 3. Green “Run” LED
- 4. Red Mat Diagnostic LEDs (10)
- 5. System Diagnostic LED

8D) Disable MPCE Monitoring

For the initial testing, MPCE monitoring must be disabled and power should not be applied to the machinery. If you have not already chosen to do so, refer to Step 3, disable MPCE monitoring and disconnect the machine control wiring connector (See Figure 8).

Figure 11

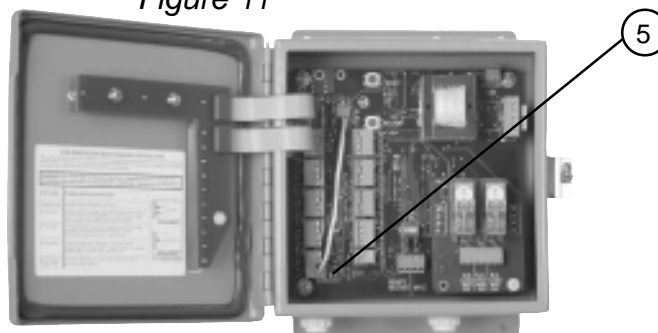

8E) Checking Operation in “Guard Only mode with no MPCE Monitoring”

(If you have chosen the automatic restart mode of operation, skip to Step 8F).

After making sure that the machinery is not powered and that the machine control wiring connector is unplugged, apply power to the Zone Monitor 5000ex while observing the indicator and diagnostic lights.

- **8E-1)** In the guard only mode of operation, as the unit was shipped, the red “Stop” and the yellow “Fault” LEDs should turn on. The green “System Diagnostic” LED should be flashing at a steady pace, and all 10 mat LEDs will turn on momentarily and then turn off.
- **8E-2)** Next, press and release the restart switch and verify that the “Stop” and “Fault” LEDs turn off and the green “Run” LED turns on. You will also see and hear the two machine control relays energize. From this point on, the green “System Diagnostic” LED should continue to flash at a steady pace unless otherwise noted.
- **8E-3)** Next apply and release pressure to safety mat 1 in the system and verify that the green “Run” LED turns off and the red “Stop” LED turn on. You will also see and hear the machine control relays de-energize.
- **8E-4)** Now press and release the “Restart” switch to return to a “Run” condition and **check each of the safety mats in the system the same way you did for mat 1.**
- **8E-5)** Next, while in a green “Run” condition, apply constant pressure to one of the safety mats and verify the same conditions as in 8E-3. With pressure still applied to the mat, press and release the restart switch while observing the mat diagnostic LEDs. The mat LED corresponding to the activated mat should turn on momentarily and then turn off.

WARNING!!! If pressure is released from the mat before the mat diagnostic LEDs turn off the unit will change to a “Run” condition immediately.

- **8E-6)** Next, while in a green “Run” condition, carefully disconnect one of the safety mats by removing one of the mat wiring connectors and verify that the unit changes to a “Stop” condition. Next press and release the restart switch and verify the “open mat circuit” indication of all 10 “Mat Status” LEDs flashing and that the unit remains in a “Stop” condition. Wait until the LEDs stop flashing, which should be within 10 seconds, then re-connect the mat, press and release the “Restart” switch and verify that the unit changes to a “Run” condition.

WARNING!!! If the mat is re-connected before the LEDs stop flashing the unit will change to a “Run” condition immediately.

If the unit does not function as described, note the condition of the indicator lights and refer to the troubleshooting guide beginning on page 16.

8F) Checking Operation in “Automatic Restart with no MPCE Monitoring”

(See Figure 4 on Page 4) With MPCE monitoring still disabled, and after making sure that the machinery is not powered and that the control output wiring connector is unplugged, apply power to the Zone Monitor 5000ex and observe the indicator lights.

- **8F-1)** In the automatic restart mode of operation, verify that the green “Run” LED turns on upon application of power without having to press the restart switch. Also note that it is normal for the 10 “Mat Status” LEDs, the red “Stop” LED and the yellow “Fault” LED to turn on momentarily prior to the green “Run” LED turning on. You will also see and hear the two machine control relays energize. The green “System Diagnostic” LED should be flashing at a steady pace and will continue to do so from this point on unless otherwise noted.
- **8F-2)** Next, while in a green “Run” condition, apply continuous pressure to safety mat #1 in the system and verify that the green “Run” LED turns off and the red “Stop” LED turns on. Within approximately two seconds, you should also see “Mat Status” LED #1 turn on. Now release the pressure to the safety mat and verify that the unit changes to a “Run” condition automatically. You may also note that some or all of the “Mat Status” LEDs flash momentarily upon activation and deactivation of the mat, which is a normal condition. If there is more than one mat in the system, **continue by checking all of the mats in the system in the same way that you tested mat 1** noting that the activated mat corresponds to the number of the “Mat Status” LED that turns on.

WARNING!!! The Automatic Restart mode of operation should not be used unless your machinery has its own “control reliable” latching stop circuitry to prevent unexpected restart.

- **8F-3)** Next, while in a green “Run” condition, carefully disconnect one of the safety mats by removing one of the 4-position connectors and verify that the unit changes to a “Stop” condition and all 10 mat LEDs begin to flash. Reconnect the mat and verify that the unit changes to a “Run” condition automatically. If the unit does not function as described, note the condition of the indicator lights and refer to the troubleshooting guide.

8G) Checking MPCE Monitoring

If you have chosen to use MPCE monitoring as the unit was shipped, testing will require feedback from your machine’s control circuit. It is therefore necessary to have power applied to the control portion of your equipment. If possible, only apply power to the control portion of the equipment when instructed to do so, while keeping the drive power of the machinery turned off. If this is not possible, be aware that the equipment will be receiving signals to start and stop during this phase of testing.

- **8G-1)** With all power to the Zone Monitor and equipment turned off, refer to Step 3 and re-enable MPCE monitoring in your desired mode of operation—guard only or automatic restart—and reconnect the control output wiring connector. Next, apply power to the machine’s control circuit and then to the Zone Monitor 5000ex and observe the indicator lights.

- **8G-2)** If you have chosen the guard only mode of operation, the lights and operational characteristics should be exactly as described in 8E-1 through 8E-6. If you have chosen the automatic restart mode of operation the lights and operational characteristics should be exactly as described in 8F-1 through 8F-3.
- **8G-3)** Next while in the green “Run” condition, carefully disconnect one of your machine’s control circuit feedback wires from the Zone Monitor 5000ex MPCE input terminal 3 or 4. Now apply and remove pressure to activate one of the safety mats and verify that the green “Run” LED turns off and the red “Stop” and yellow “Fault” LEDs turn on. You should also note that the system diagnostic LED is signaling a two flash beat and that the LED for mat 1 is on.

Now reconnect the feedback wire. If the unit is in the guard only mode, press and release the reset switch, then press and release the restart switch and verify that the unit changes to a “Run” condition and the system diagnostic LED returns to a steady beat. If the unit is in automatic restart mode it should change to “Run” condition by pressing and releasing the reset switch only.

If the unit is not functioning as described, note the condition of the indicator lights and refer to the troubleshooting guide beginning on Page 15.

8H) Checking the Machinery

Use Extreme Caution!!!

Be aware that with some machinery, sudden stopping and starting could be a hazard in itself. Take every precaution when entering the protected area to activate and test the safety mat system. If all is working as expected, you may now apply machine drive power and check that the equipment stops and starts as expected when stepping on and off of the safety mats.

Appendix A

Glossary

Activated Mat

Refers to a safety mat in a closed circuit condition. This is the normal condition for a mat with pressure applied to it.

Automatic Restart Mode

The automatic restart mode of operation allows your machine to resume operation immediately once an activated mat is cleared. When not in automatic restart mode, the control unit is in guard only mode, which requires deliberately pressing the restart switch to re-activate your machinery.

WARNING! The automatic restart mode of operation should not be used unless your machinery has its own “control reliable” latching stop circuitry to prevent unexpected restart.

Control Unit

A control unit responds to signals from sensors (in this case, safety mats) and sends signals to control the state of the machine it is controlling. In addition to performing this function, the Zone Monitor 5000ex control unit monitors mats and machinery for faults.

Electrostatic Discharge (ESD)

Commonly known as “static electricity,” this is the sudden movement of electrons between two objects with different electrostatic potentials. ESD can potentially damage or destroy electronic components if proper procedures are not followed.

External Control

External control refers to the remote restart feature of the Zone Monitor 5000ex control unit. Using this feature allows your Zone Monitor to be restarted after a stop or fault condition through the use of a remotely located momentary contact switch (in guard only mode).

Fault Condition

When the yellow “fault” LED is lighted, the Zone Monitor 5000ex is indicating an internal fault condition or an improper MPCE feedback signal (when MPCE monitoring is enabled). The red “stop” LED will light as well. Refer to Appendix D for troubleshooting information.

Feedback

Communication between your Zone Monitor and the guarded machine through MPCE signals—only available with MPCE monitoring enabled.

Guard Only Mode

When the Zone Monitor 5000ex is in guard only mode, you must press the restart switch (located on the internal circuit board) each time the control enters a stop condition. When not in guard only mode, the unit is in automatic restart mode.

LED

LED stands for light emitting diode, a light used in the mat status and diagnostics systems.

Mat Lead

Each Larco safety mat has a 4-wire cord or mat lead that is connected to the control unit.

MPCE Monitoring

MPCE stands for machine primary control element. When enabled, your Zone Monitor 5000ex will monitor the MPCE signal produced by the guarded machine to ensure it is functioning properly with respect to “run” and “stop” conditions of the Zone Monitor 5000ex.

Remote Restart

The remote restart option on your Zone Monitor 5000ex enables you to restart your control unit after a stop condition through the use of a remotely located momentary contact switch (in guard only mode).

Run Condition

When the green “run” LED is lighted, your machine is in run condition, which means the Zone Monitor 5000ex is sensing a signal telling your machinery to run.

Stop Condition

When the red “stop” LED is lighted, your Zone Monitor 5000ex is sensing a stop signal, which means the machine control relays will be de-energized due to mat activation or a detected system fault.

Appendix B

Dimensional Drawing & Specifications

Controller Specifications

Performance	
Operating Area	Up to 200 sq. ft. mat area per controller
Response Time	<30 milliseconds
Indicators	Run = Green LED Fault = Yellow LED Stop = Red LED Mat Status = 10 Red LEDs Internal Diagnostics = Green Heartbeat LED
Operational Modes	DIP switch-selected automatic restart and guard only modes
Electromagnetic Compatibility (EMC)	
Electrostatic Discharge (ESD)	+/-10kV (air discharge) +/-6kV (contact discharge)
Radiated RF Field	10 volts/meter, 100 to 1,000 MHz
Electrical Fast Transients (EFT)	+/-1kV (power supply) +/-0.5kV (control signals)
Misc.	
Reset & Restart Functions	Internal manual pushbuttons Optional remote restart
Mat Input Connectors	Up to 10 plug-in connectors
Enclosure	Steel (Powdercoat Machinery Grey) 8" h x 8" w x 4" d (203 mm x 203 mm x 102 mm)
Mounting	Surface Mount
Shipping Wt.	11 lbs

Electrical

Power Input	120 VAC (+10%/-15%), 240 VAC (+10%/-15%) 50/60 Hz 24 VDC Option (+/- 10%)
Safety Inputs	Connections for up to 10 4-wire safety mats
Safety Output Relays	Standard: Two SPDT captive contact relays with two closed when run (NO) and one open when run (NC) sets of contacts rated 8 amps at 230 VAC Optional: Three closed when run (NO) and two open when run (NC) sets of contacts rated 10 amps at 240 VAC
MPCE Monitoring	DIP Switch Selected
Optional Aux. Output Relay (not safety rated)	One SPDT Form C relay with one closed when run (NO) and one open when run (NC) contact rated 10 amps at 250 VAC
Relay Life	Mechanical: 10,000,000 operations Electrical: 500,000 operations at 1 amp at 240 VAC

Environmental

Enclosure Rating	NEMA 12 & 13, IP 54, UL50
Operating Temperature	32 F to 121 F (0 C to 50 C)
Relative Humidity	20-90%
Standards of Conformity	Designed to meet or exceed UL 508 Safety for Industrial Controls, ANSI B11.19 Machine Tool Safety Standards, OSHA 1910.212 General Machine Guarding, and RIA 15.06 Robotic Safety Requirements

Figure 12

Legend:

measurements in mm: [xxx]

measurements in inches: xxx

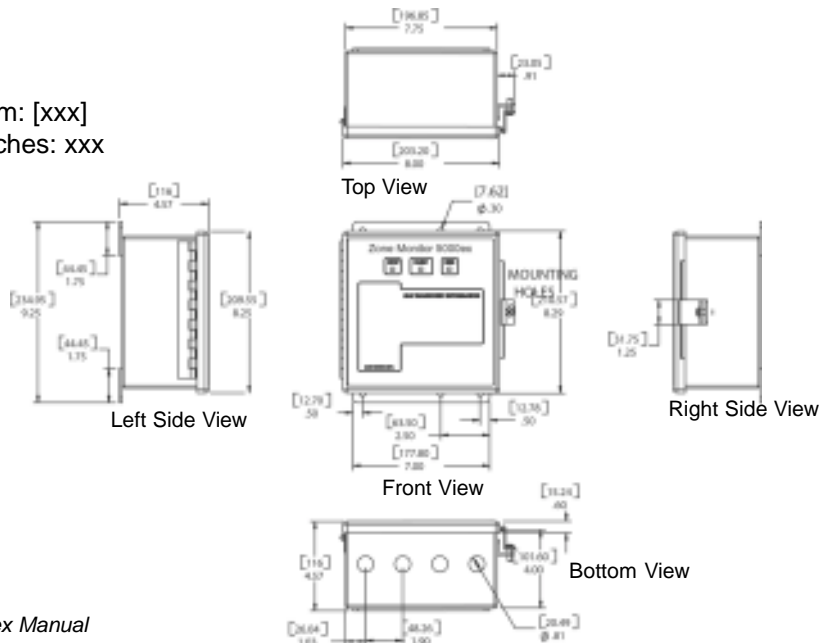

Appendix C

Guide to Diagnostic Lights

WARNING!!! If you are diagnosing the installation, be aware that some of the following instructions for clearing fault conditions would cause the machinery to start depending on your mode of operation. Make sure the area is clear of personnel and the machinery is powered down before proceeding with caution.

Green “System Diagnostic” LED

Steady Flash: Indicates normal operation.

2 Flash Beat: Indicates MPCE Feedback fault. The feedback is not there, took too long (greater than 200 ms) or is in the wrong state. Check the MPCE wiring, MPCE signal (should be normally closed or open when run) and the source of signal. Then press the reset switch to clear this fault. Refer to step 3C & 5B for more information.

3 Flash Beat: Indicates incorrect option selection configuration. Correct the configuration and cycle incoming power to the Zone Monitor to clear this fault. Refer to step 3 for more information.

4 Flash Beat: Indicates a problem with the Zone Monitor’s machine control relays due to a timing discrepancy between the pair or a response/sequencing fault. Press the reset switch to clear this fault. Note: if the unit is configured in the guard only mode of operation, you will also need to press the restart switch to clear this fault and return to normal operation. If the problem persists, replace the relays.

8 Flash Beat: Indicates internal error with the Zone Monitor 5000ex. Remove and restore incoming power to the unit to clear this fault. If the problem persists, contact the factory for instructions.

Continually On: Indicates a failed internal safety processor. Contact the factory for instructions.

“Mat Status” LEDs 10 Red

All Off: Indicates normal operation with no pressure applied to mats.

Continually On: Indicates an activated Safety Mat(s). The number of the LED that is on corresponds to the Safety Mat that is activated. If the layout contains more than one mat and more than one mat is activated simultaneously, the LEDs will indicate only the first mat activated in the series. Note: when the unit is configured in “Guard Only” mode and a mat is activated, only mat LED number 1 will turn on. When the restart switch (item number 11 on figure 2) is pressed and released the correct number of LEDs will turn on for approximately 5 seconds to indicate the activated mat.

Figure 13

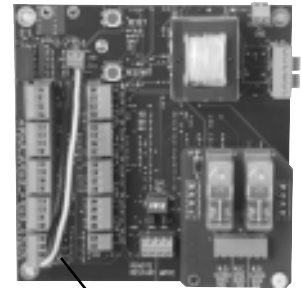

● System Diagnostic LED

Figure 14



● Mat Status LEDs

Appendix D

Troubleshooting Guide

WARNING!!! If you are diagnosing the installation, be aware that some of the following instructions for clearing fault conditions would cause the machinery to start depending on your mode of operation. Make sure the area is clear of personnel and the machinery is powered down before proceeding with caution.

Condition: All lights are off.

Probable Cause

- No power to the Zone Monitor 5000.
- Poor (loose) connections.
- Improper configuration of power connector.

Solution

- Test for incoming power.
- Recheck terminal block for screw-clamp tightness & receptacle position.
- Refer to Step 7 and recheck configuration.

Condition: Red “Stop” LED stays on.

Probable Cause

- Broken or intermittent mat wire connection.
- Activated mat or shorted mat wire.
- The unit is in guard only mode and is waiting for a restart signal.

Solution

- For mat or mat wire problems, refer to the “Mat Status” LEDs in Appendix C, correct the situation & restart the system.
- Refer to step 3A and 5A regarding restart in guard only mode.

Condition: Yellow “Fault” LED stays on.

Probable Cause

- Machine control relay contact has failed.

Solution

- Replace output relays.

Condition: Yellow “Fault” and Red “Stop” LED stays on.

Probable Cause

- The Zone Monitor was powered up in guard only mode and is waiting for a restart signal.
- A type of fault has been detected.

Solution

- The restart switch must be pressed to achieve a run condition after power-up in guard-only mode. For more information refer to Steps 3A and 5A.
- Refer to the “Green System Diagnostic LED” in Appendix C, correct the problem and restart the system.

Condition: Green “Run” LED stays on but machine will not operate.

Probable Cause

- The machine control relay signal is not reaching the machine control.
- A different device or machine interlock is preventing operation.

Solution

- Check the wiring to the machine from the machine control connector to the machine’s control connection point.
- Replace the machine control relays of the Zone Monitor.
- Check for other machine interlocks that may be preventing operation.