

300-310 MHz 12-24V Receiver Installation Instructions



The power of control. Automated.

Access the Jumpers and DIP Switches

1 Open the access door by sliding it to the right. See Diagram 1.

You can now see the jumper and dip switches. See Diagram 2. The receiver will automatically detect voltage between 12-24 V, either AC or DC.

Set the Jumpers

2 Determine the operating frequency you will use on your installation. The receiver can operate at either 300 MHz or 310 MHz.

At 300 MHz the receiver is compatible with all MultiCode® transmitters with 10 dip switches operating at 300 MHz. At 310 MHz the receiver is compatible with all Linear® transmitters with 8 dip switches and Stanley® transmitters with 10 dip switches operating at 310 MHz. See Diagram 2.

- A. For 300 MHz with 10 dip switches, jumpers S1 and S2 must be in place.
- B. For 310 MHz with 8 dip switches, jumpers S1 and S2 must be removed.
- C. For Stanley® 310 MHz with 10 dip switches, jumper S1 must be removed and jumper S2 must be in place.

Set the DIP switches

3 Set the dip switches to the desired settings to match your transmitters. SW1 controls Relay 1 and SW2 controls Relay 2. See Diagram 3.

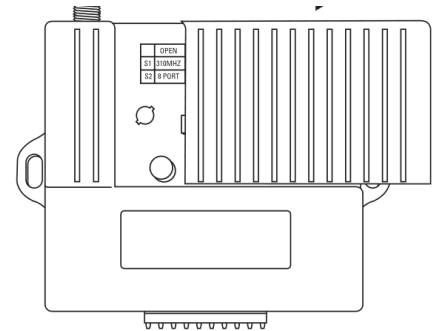

Diagram 1: Getting Access to Codes

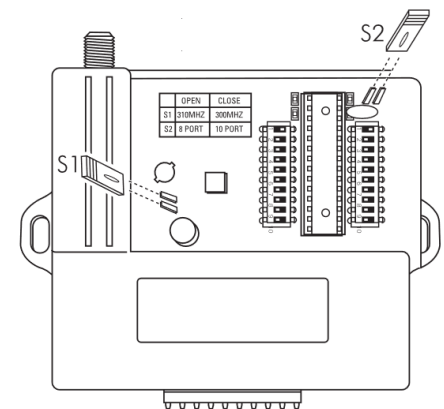

Diagram 2: Setting the Jumpers

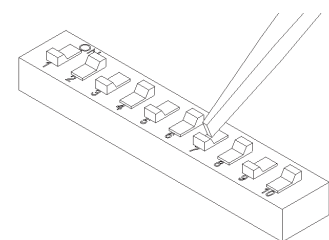

Diagram 3: Setting DIP Switches

300-310 MHz 12-24V Receiver

Installation Instructions (cont.)



The power of control. Automated.

Wire the Receiver Harness

- 4** Wire the receiver harness according to the wiring diagram. For ease of installation the wires are color coded. For most standard gate and door installations you will wire the open input of your gate operator or garage door, with the common and NO (normally open) contact of either relay 1, 2 or both. See Diagram 4.

Testing

- 5**
- A. Attach the wiring harness to the receiver. See Diagram 5.
 - B. Verify the receiver has power. This can be verified by observing if LED1 and LED2 are illuminated. See Diagram 6.
 - C. Push the button on a transmitter that has been programmed to the same code as the receiver. If you hear the relay click and see the LED flash quickly, you have successfully wired the receiver.
 - D. Close the access door on the receiver. See Diagram 7.

Installation

- 6** Mount the receiver in a safe and convenient location on your installation. Remember to take care to avoid items that may cause interference with the receiver such as electric motors, etc. The receiver can be attached with either the mounting screw holes of the housing or by using industrial strength velcro.
- A. Install the coax antenna (provided) by screwing it onto the antenna mount which protrudes from the top of the housing.
 - B. After you have completed the installation check for operational range from various areas around the installation. If the range is less than desired, try re-positioning the antenna, receiver, or both and re-test the range.

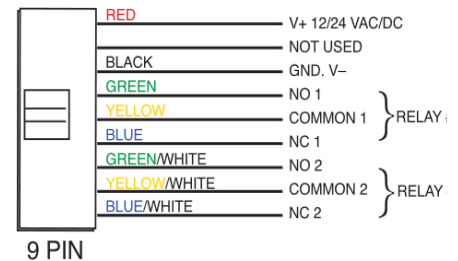

Diagram 4: Receiver Terminal Map

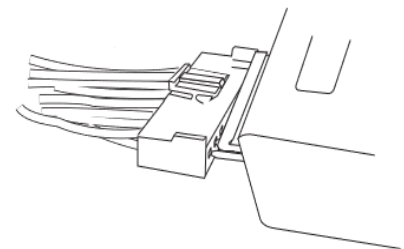

Diagram 5: Attach wiring harness to the Receiver

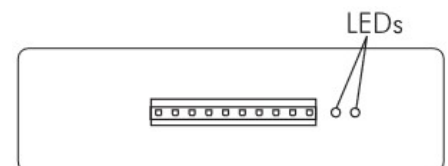

Diagram 6: Check for illuminated LED's

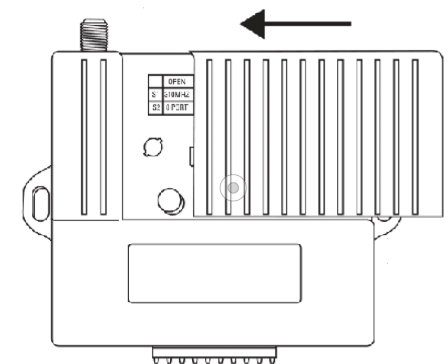

Diagram 7: Close the access door

223-0204-000 Rev. A 12/22  WARNING: Cancer and Reproductive Harm - www.P65Warnings.ca.gov

ATEK Access Technologies
10025 Valley View Road, Ste. 190
Eden Prairie, MN 55344 U.S.A.

PH: 1.800.523.6996
FAX: 1.800.589.3705
+1.218.829.9797

www.atekaccess.com



Access the power of technology.